

TO3000 Process Trace Oxygen Analyzer

Technical Specifications

Measure Range:	0-10, 0-100, 0-1000ppm, 0-1% FS ranges;
Accuracy:	<±1% of FS range under constant conditions;
Application:	Oxygen analysis from 0.5ppm to 1% in inert, helium, hydrogen, mixed and acid (CO ₂) gas streams;
Approvals:	ISO9001:2008;
Area Classification:	General purpose;
Alarms:	2 adjustable form C relay contacts non-latching;
Calibration:	Certified gas of O ₂ balance N ₂ approximating 80% of range above analysis range recommended for optimum results; Two points calibration;
Compensation:	Barometric pressure and temperature; optional heated sample system and sensor housing;
Connections:	1/4" or 1/8" lock type tube fittings;
Controls:	Menu driven calibration, alarm and system functions;
Data Acquisition:	Selectable data point intervals;
Display:	Graphical LCD 128×64MM; resolution 0.01 ppm, display pressure, measure range, real time and date;
Enclosure:	Painted aluminum 144 (H)×144 (W)×251 (D) MM;
Flow Sensitivity:	1~1.5L/min recommended;
Pressure:	Inlet - regulate to 0.5~2 bar, Vent – atmospheric;
Power:	Universal; AC110~264 VAC, 50/60Hz;
Response Time:	90% of final FS reading < 10 seconds;
Sample System:	Flow control and sample/bypass valves; flow indicator;
Sensitivity:	< 0.5% of FS range;
Sensor Life:	24 months at 25°C and 1 atm; average O ₂ < 1000 ppm;
Signal Output:	4-20mA isolated or 0-10V (optional), etc;
Temp. Range:	0~50 °C ;
Warranty:	12 months analyzer; 12 months sensor;



Advanced Sensor Technology

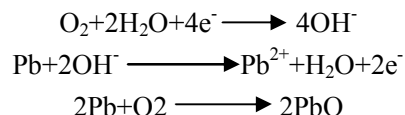

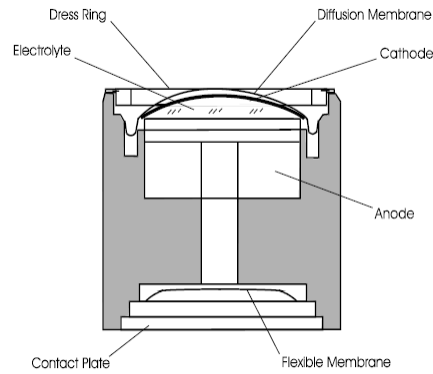

Standard Features

- Fast recovery Insta Trace Micro-fuel Cell sensor;
- Screen touch sensing type button operation, unique operation experience;
- Signal output 4-20mA or 0-10V (optional), etc;
- Two fully-adjustable concentration alarm points with programmable relay function;
- Full duplex RS232 communication link;
- Universal power supply 110-230 VAC 50-60Hz;
- Extended-life, maintenance-free sensor;
- Special bypass sample system and software purity settings to protect sensor;
- ISO 9001 QA System.

Applications

- Air separation and liquefaction
- Pure, gaseous hydrocarbon stream monitoring
- Semiconductor manufacturing
- Protective atmosphere blanketing of primary liquid feedstocks and flammable liquids
- Process monitoring of gaseous monomers-vinyl chloride, propylene, butadiene, isoprene or ethylene
- Gas purity certification

Install

